

RESISTRON

TEMPERATURE CONTROLLER
FOR HEATSEAL BANDS
TO SEAL PLASTIC FILMS

RES-222



Features

- ★ Easy mounting into the control panel
- ★ Signal "Set-point reached" ($T = T_s$)
- ★ Temperature indicator in °C
- ★ Comprehensive monitoring with "Alarm Signal"
- ★ Easy Installation and Operation
- ★ Perfect for Large Variety of Application

TABLE OF CONTENTS

A	GENERAL SAFETY INSTRUCTIONS	2	C	GENERAL INSTALLATION INSTRUCTIONS	3
B	PROPER COMPONENT SELECTION	2	D	PREVENTIVE MAINTENANCE	3
B.1	Heatseal Band	2	E	STANDARDS	3
B.2	Transformer	2	F	WARRANTY	3
B.3	Current Transformer	2			
<hr/>					
1	APPLICATION and SHORT DESCRIPTION	4	7	HEATSEAL ELEMENTS	12
2	PRINCIPLES of OPERATION	5	7.1	Change of Heatseal Elements	12
3	FUNCTIONS	6	8	OPERATING MODES	13
3.1	Measuring or Regulating Mode	6	8.1	Constant Heat	13
3.2	Zero Calibration	7	8.2	Impulse Sealing	13
3.3	Start	7	8.2.1	Timing at Impulse Sealing	14
3.4	Signal "Set-point reached" ($T=T_s$)	8	8.3	Using signal "Set-point reached"	15
3.5	Alarm	8	9	PHYSICAL DIMENSIONS	16
3.6	Reset	8	10	TECHNICAL SPECIFICATIONS	17
4	WIRING DIAGRAM	8	10.1	How to Order	18
5	POWER SUPPLY	9	11	INSTALLATION INSTRUCTIONS	19
5.1	Line Filter	10			
6	OPERATING INSTRUCTIONS	11			

A GENERAL SAFETY INSTRUCTIONS

This product is manufactured according to DIN EN 61010-1, quality assurance tests were conducted throughout manufacturing.

The unit is delivered from the factory in perfect condition. All instructions, advice and warning contained in this Operating Manual must be strictly adhered to to ensure the safe usage of the unit.

This unit can be operated within the limits listed under "Technical Data". It must only be installed, connected and operated by trained personnel.

Maintenance and Repair may only be performed by factory trained personnel that understand all safety precautions.

A.1 Usage

RESISTRON controllers may be used only for the heating and controlling of heatseal bands of proper composition and quality, such as Toss Alloy-20. Disregarding these instructions, or using this unit for

purposes other than described, may result in overheating and permanent damage to the heatseal band, the electrical wiring, the transformer or the controller.

B INSTRUCTIONS TO BE OBSERVED



B.1 Heatseal Element

A precondition for the proper function and safety of the system is the use of the



proper heatseal element

The heatseal element must have a positive temperature coefficient of resistance that is consistent with the controller calibration.

Using unsuitable alloys will cause uncontrollable heating and



heatseal element burn-out.

Look for the identifying markings of your original qualified supplier such as, Trademark, connector design, or certification to avoid unsatisfactory substitutes.

B.2 Transformer

The transformer must be built according to VDE 0551 (disconnecting transformer with increased isolation). If the transformer is not mounted in the electrical cabinet, but in the machine itself, a protective housing must be

provided. Furthermore, it must be protected from spray of water, cleaning liquids or contact with any conductive materials.

Disregarding these safety instructions is hazardous.

B.3 Current Transformer

The current transformer supplied with the unit is part of the overall system. Only an **ORIGINAL ROPEX Current transformer** can be used. Do not use the current transformer with terminals open; that is, without being properly connected to the controller.

Additional safety features are mentioned in "Wiring Diagram" (Section 5 "Power Supply").

For additional operating safety also see our brochure "Monitoring Modules".

C GENERAL INSTALLATION INSTRUCTIONS

Controllers of the series 20x and 40x are suitable only for mounting into the electrical cabinet. Outside mounting is not allowed.

The unit as well as the current transformer are secured on a 35mm mounting rail (DIN EN 50022). When mounting several controllers onto the same rail, a

distance of at least 20mm between the individual controllers must be maintained. When mounting the controller, adequate space and ventilation must be provided to avoid overheating. The heat generated by adjacent components must also be taken into consideration (please see "ambient temperature").

D PREVENTIVE MAINTENANCE

No special preventive maintenance is required. Occasional retightening of the mounting screws is

recommended. Dust accumulation can be removed with dry air.

F WARRANTY

A 6 months warranty conditional is made in accordance with the German law. All units are factory tested and calibrated prior to shipment. Excluded the warranty are units damaged due to incorrect wiring, impact, electrical overload, normal wear and tear, faulty and

careless handling, chemical liquids or mechanical overload, as well as units physically changed by customers, or in attempt to repair.

Any claim under warranty must be approved by the factory.

1 APPLICATION and SHORT DESCRIPTION

As all other **RESISTRON** controllers, this unit is used to control the temperature of heating elements (heatseal bands, beaded bands, cutting wires, etc.) by measuring the resistivity of the heating element.

Precision measurement together with high response produces perfect temperature control during the heatsealing process.

With a correctly installed system, the temperature can be controlled with an accuracy of +/- 3%.

This controller can be used in a large variety of applications since it can be set for a few milli-ohms or several ohms by means of dip switches, as well as high output voltage for a short time up to 10KVA (at 400V).

This unit is excellent for

- **horizontal and vertical packaging machines**
- **form/fill/seal machines**
- **bag filling and closing machines**
- **wrapping machines**
- **bag making machines, etc.**

The electronic components are mounted in a compact housing to be installed into the control panel (72x144mm). The front of the controller displays all of the operating and output functions. Wiring is kept to a bare minimum.

The front panel is protected by means of a clear plastic latchable cover.

Comprehensive self-monitoring of the internal and external circuits provides additional operating reliability (please see "Alarm").

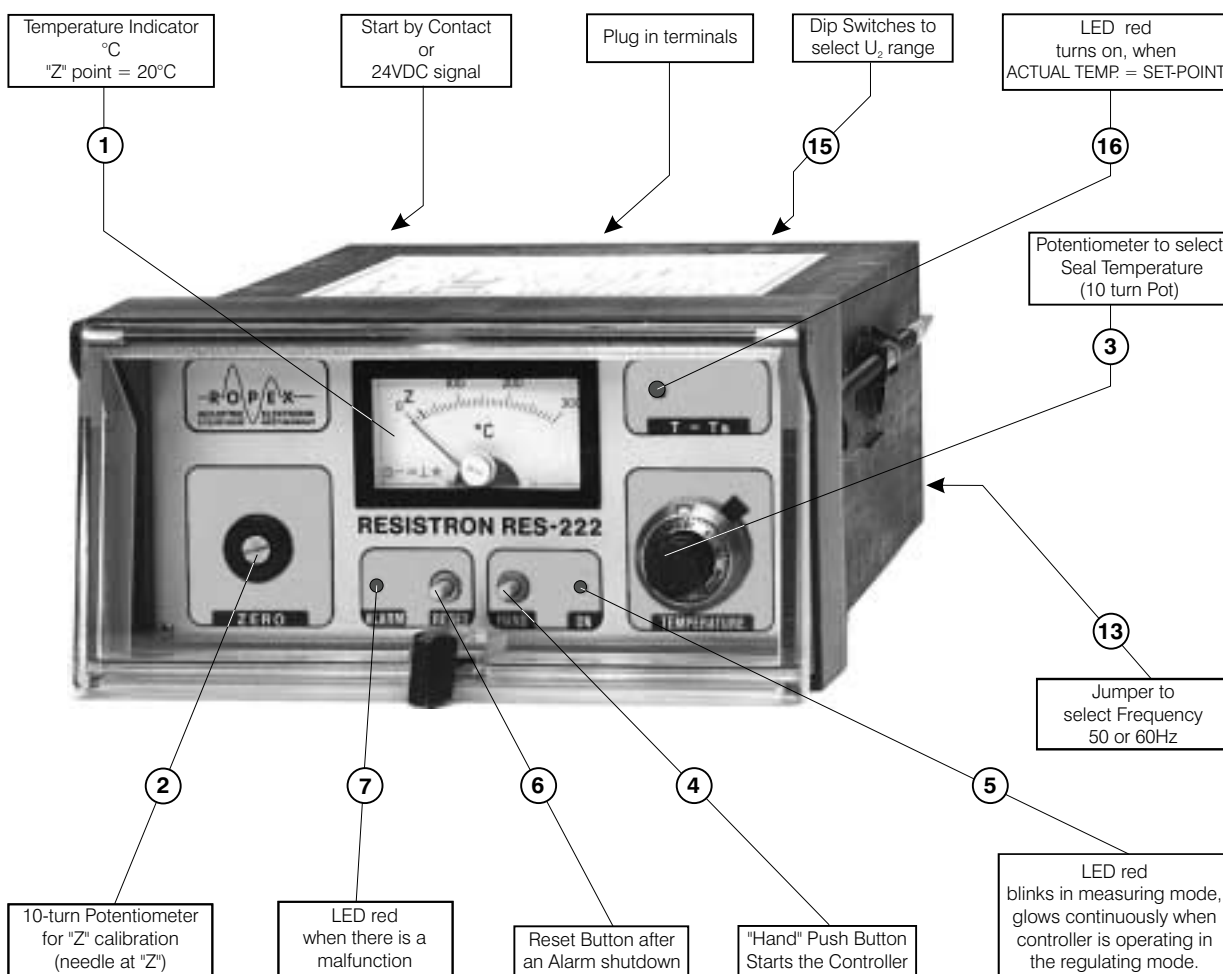

2

PRINCIPLES of OPERATION

RESISTRON controllers are electrical resistance-measuring, temperature regulating units. They use the characteristics of certain heatseal elements that change their resistance in a fixed ratio to the change in temperature.

This characteristic of the heating element is expressed by its temperature coefficient T_k .

For a dependable temperature control the heating element must have a coefficient of $T_k \geq +8 \times 10^{-4} \text{ K}^{-1}$.

The resistance is constantly monitored (50 times per second with 50 Hz; 60 times/second with 60 Hz) by

measuring the current through the element and the applied voltage. This information is fed back to the controller as the process variable "PV". It is also supplied for display on the temperature meter. After comparing this information with the set point "SP", the controller adjusts the voltage output to the heating element so that it will always maintain the desired temperature (resistance). Voltage control is accomplished by phase-angle-control of the primary current going to the transformer.

The high response feed back facilitates extremely fast temperature changes.

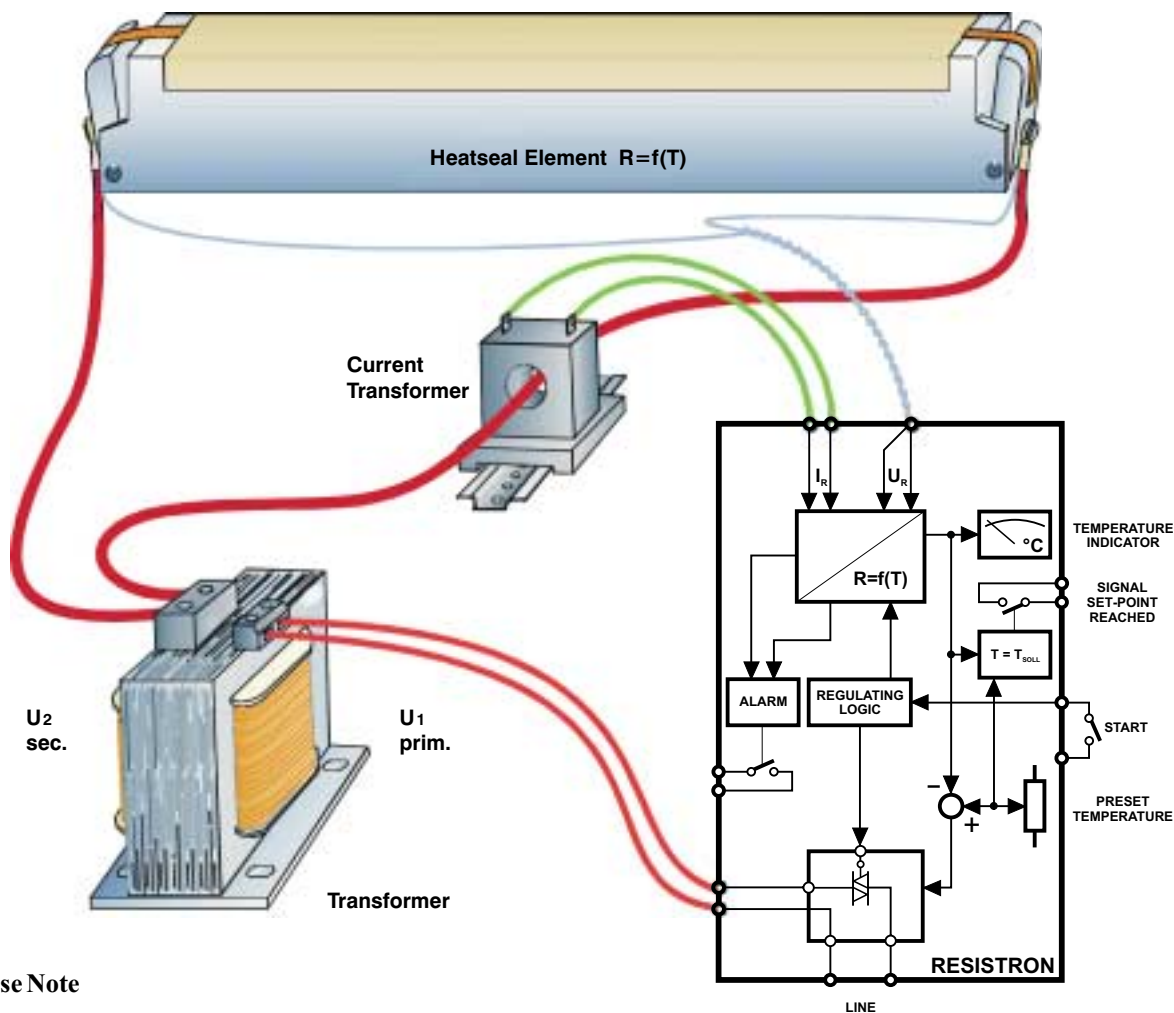

Please Note

The **RESISTRON temperature controllers** are important components for modern machines with higher speeds. The technical possibilities offered by this control system however, can only be achieved by optimizing the **complete system**.

The heatseal element, the heatseal transformer, the wiring, the signaling, and the controller **must be perfectly matched for best results**.

We will be happy to help you optimize your system with the right design and selection of components. Many years of experience are at your disposal.

3 FUNCTIONS

3.1 *Measuring or Regulating Mode*

With power supplied to the controller, the **measuring mode** is active when there is **NO** start signal. The controller sends short, low energy pulses (every 10 cycles) to the heatseal element. This measuring pulse constantly monitors the actual heatseal band temperature without significantly raising its temperature.

In the measuring mode the LED "ON" blinks with a frequency of 5 or 6 Hz in synchronism with the calibration pulse.

When the **START signal** is activated, the controller goes into the **regulating mode** increasing the

temperature of the heatseal element to the desired set point as rapidly as possible using the maximum available power

$$(P_{\max} = U_2^2 / R).$$

Concurrently, the measuring rate increases by 10 times to 50 times/sec at 50Hz, or 60 times/sec at 60Hz. The maximum secondary voltage is supplied to the heating element and then subsequently reduced by the phase control function as the preset temperature is approached.

The LED "ON" is constantly illuminated.

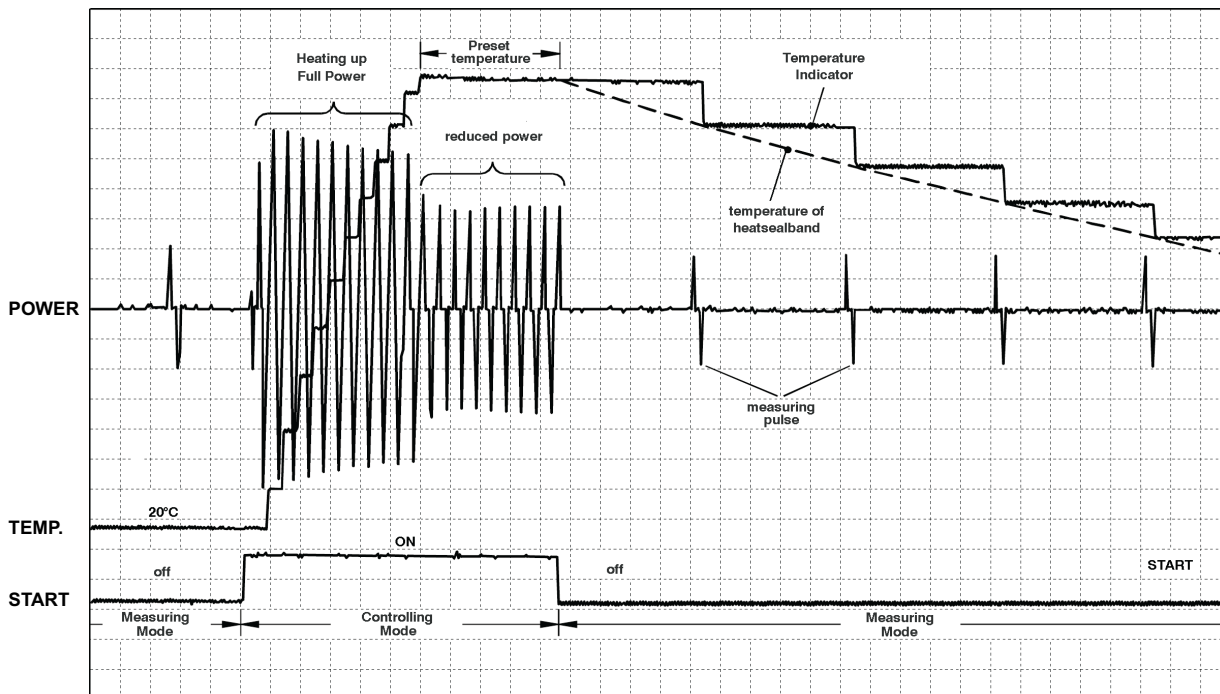

3.2

Zero Calibration

The 'zero calibration' is the adjustment of the controller to the resistance of the cold heatseal band at room temperature (20°C, 68°F), assuming that the heatseal band and the heatseal jaws are at room temperature, using the "ZERO" potentiometer to set the needle of the analog meter to "Z". Theoretically one could use another reference point as long as the temperature of the heatseal band is known.

Since the 'Z' point depends upon the size of the heatseal element (length and cross section), the "Z" point should be readjusted after each change of heatseal band, especially when the heatseal band size is changed.

Also please see - "Heatseal Elements" (burn in effect) "Operating Instruction"

Zero calibration is always performed in the measuring mode; NO "START" signal may be given, and the LED "ON" must be blinking!

3.3

Start

With the "START" signal activated, the regulating mode (preset temperature vs. actual temperature) starts; the controller switches from the measuring mode to the regulating mode, heats up the heatseal element to the preset temperature, and will maintain this precise temperature as long as the "START" signal is on.

The controller has **START BLOCK** feature which will prevent overheating of the heatseal element if the controller has not been properly zero calibrated.

When the "START" signal is turned off, the controller reverts to the measuring mode, and the heatseal element will cool down. The cooling can be observed at the analog meter.

This happens if the meter needle is below the electrical zero point. The heatseal band will not heat up even though the "ON" LED indicates that the controller is in the regulating mode.

The "START" signal can be given in three different ways:

The controller remains blocked, until the Z-Point has been readjusted.

- pushing the "HAND" button on the front panel
- closing a relay contact between terminals 2 and 7
- applying a 24VDC signal across terminal 3 and 4

ATTENTION:

New heatseal elements will reduce their resistance after the first burn-in. When the element is cooled off completely, the needle may fall below the "Z" point, please recalibrate, or the controller may not start. (please see "Heatseal Elements" (burn in effect))

NO START,
when needle
in this area

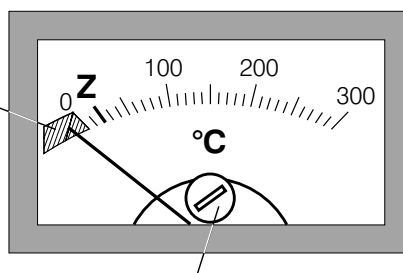

Mechanical "0" point, **DO NOT CHANGE !**

3.4

Signal " Setpoint reached " (T=Ts)

Approx. 15°C before reaching the preset temperature the controller indicates "temperature reached".

controlled within a symmetrical range of ±15°C, travelling with the set-point.

The LED (16) (T=Ts) on the front panel turns ON and the output relay "temperature reached" is activated.

The dry contact of the relay (terminals 16,17,18) can be used for external control or monitoring functions. (→ control example signal" setpoint reached" T=Ts)

This function operates also with a positive deviation of +15°C of the setpoint which means that temperature is

3.5

Alarm

To increase operating safety and to assure adequate seals, the RES-222 controller contains a comprehensive monitoring system that will send an alarm signal (LED "ALARM"(4) will turn red) and activate the alarm relay when:

- a) Heatseal element breaks, or any discontinuity in the secondary circuit occurs.
- b) When one of the heatseal element breaks when two are connected in parallel.
- c) A short circuit occurs at the heatseal element.
- d) Any discontinuity occurs in the monitoring wiring for voltage U_R or I_2 .
- e) Heatseal element overheats by 20 % over the maximum temperature (hotter than 360°C).
- f) Calibration was performed incorrectly (suppression of the "Z" point). (please see "Start" and "start block")

In order to permit a proper calibration functions e) and f) are activated only when there is a start signal.

Other reasons for an alarm signal could be:

- **Incorrect voltage range chosen (DIP switches 15)**
- **Incorrect frequency rating selected (Jumper 13)**
- **Incorrect voltage supply (e.g. 230V vs 115V)**
- **Internal malfunction**

The malfunction is signaled by the LED "ALARM". The controller output is disabled and will remain in this state. The alarm relay is activated (contact between 5 and 6 is closed).

3.6

Reset

The controller can be reset - after the cause of the malfunction has been corrected - by pushing the "RESET" button, or by turning off the main power by at least 1 second.

4

WIRING DIAGRAM

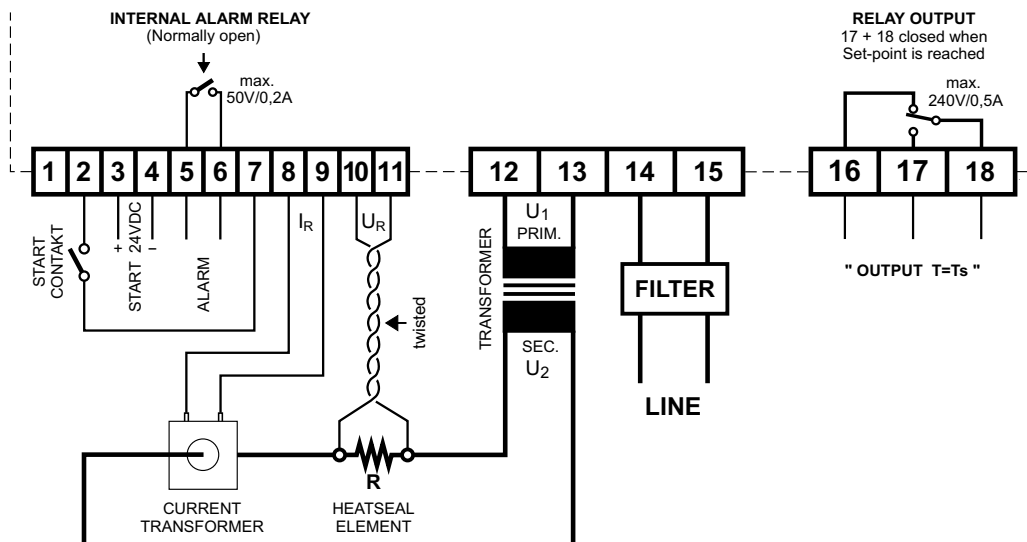

5

POWER SUPPLY

Protection devices, Line Filter, wires cross sections

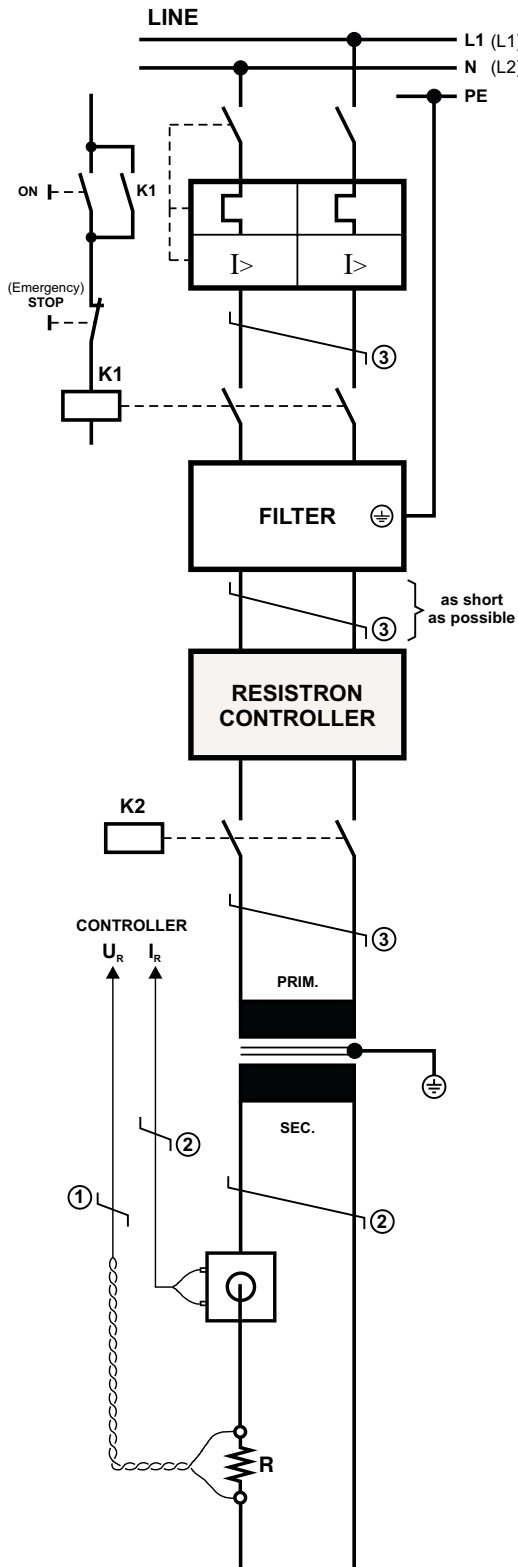

LINE:
230VAC, (or 400VAC)
+10% / -15%, 50/60Hz

CIRCUIT BREAKER:
Double-pole, characteristic Z,
Nominal current: 16A
e.g. ABB-STOTZ Type S282-Z16
(for all applications)

CONTACTOR K1
For eventual function "HEAT ON-OFF" (double pole)
or "EMERGENCY STOP"

LINE FILTER to comply with the EMC noise limits.
Type and size of filter have to be determined depending on load,
transformer and machine wiring.
ROPEX-Filters are suitable for the most applications and
correspond to the EMC-Standards.
(please see separate description).

CONTROLLER
All RESISTRON-Controllers of the series 2XX and 4XX.

CONTACTOR K2
Load break (double pole)
e.g. in connection with the alarm signal of the controller.

TRANSFORMER
Designed according VDE 0551
(safety transformer with increased isolation).
Connect core to ground
(Do not use side by side winding-design).
Power, duty cycle and voltage values have to be determined in
accordance of the application
(please see application report).

WIRING

INSTALLATION

- ① Absolutely necessary to twist.
- ② Recommended to twist, specially if various controllers are working together ("cross-talk interference")
- ③ Recommended to twist, improvement of the EMC.

Do not lay the filter lead wires (Line-side) parallel to filter output wires (Load-side).

CABLE CROSS-SECTION

Depend on the application
(please see applications report)

GUIDE VALUES:

Primary circuit:
(line to transformer primary side)
min. 1,5mm², max. 2,5mm².

Secondary circuit:
Strongly depending on the application
from 4mm² bis 25mm².
(please see applications report)

Measuring wires:
min. 0,5mm².

Measuring wire for U_R to be twisted
with ≥ 37 Lays/m.

5.1

Line Filter

In order to observe the EMC regulations RESISTRON control circuits have to operate with Line noise filters for two reasons:

1. Attenuation of noise emission into the power line originated from the phase-control of the RESISTRON
2. To prevent noise values from being entered into the controller

Filters, therefore, have an influence over emission of noise and noise immunity of the systems as well.

Other influences such as variety of load (dimensions of heatseal element), operation mode (impulse, constant heat, duty cycle), wiring and line voltage (115V, 230V, 400V) make it difficult to select filters as all criteria have to be observed.

In order to determine the appropriate filter there are usually several and expensive noise voltage measurements necessary.

ROPEX-Line- Filters are specially designed for use in RESISTRON-Control-Circuits.

Installation and wiring according to our suggestions will meet with the requirements of EN 50081-1 and EN 50082-2 standards.

The high voltage rating of 480VAC permits to operate filters upto 400VAC.

For most applications nominal current of 6A with upto triple impulse load is sufficient.

In case of extreme load we will be happy to assist you. Observe further advices in section "power supply" regarding wiring.

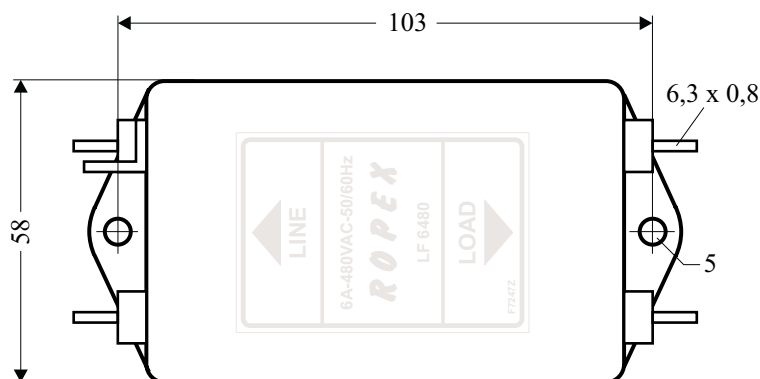
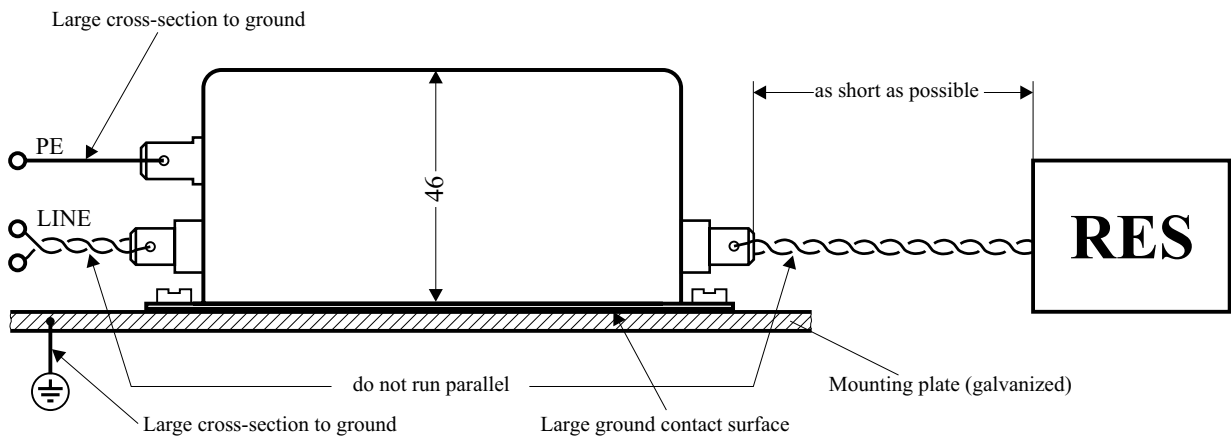

Line Voltage:	480V, 50/60Hz
Operating current:	6A
Peak current:	ca. 20A at 20% Duty cycle
Ambient temperature:	40°C

It is admissible to operate several RES-Control-circuits with one filter as far as the total current does not exceed the filter current.

Remark: the use of an appropriate Line Filter is part of the standard conformity and **prerequisite for the CE-Label**

6

OPERATING INSTRUCTIONS

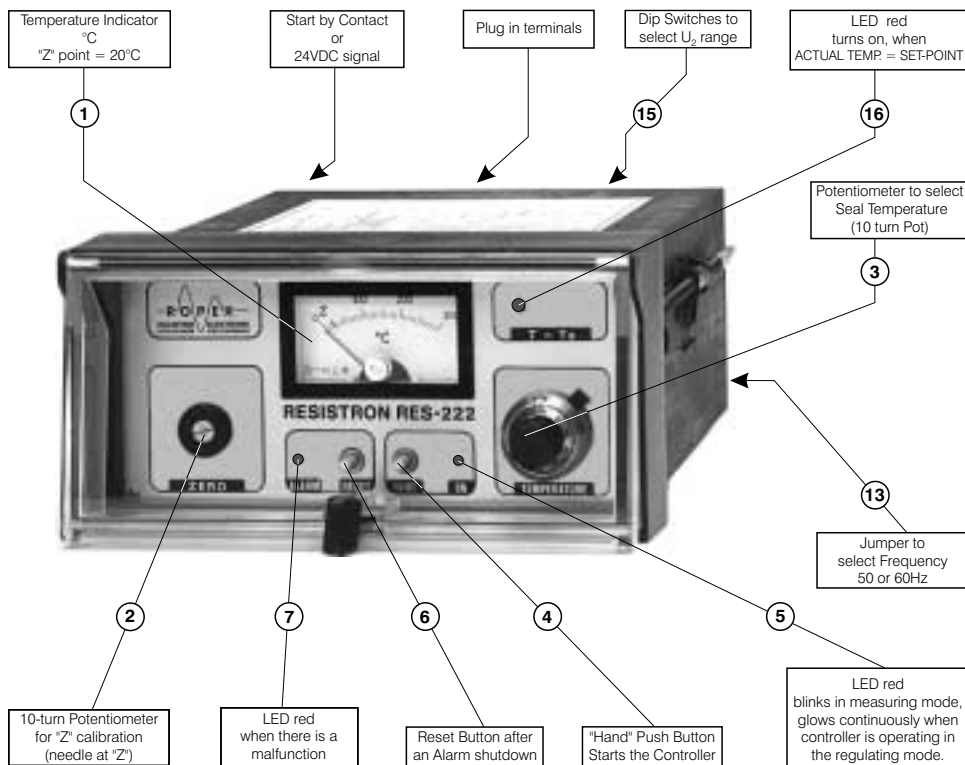

6.1

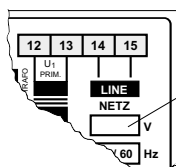

Examine the controller and determine that the power to be supplied to the controller is in agreement with the controller's voltage specification.

6.2

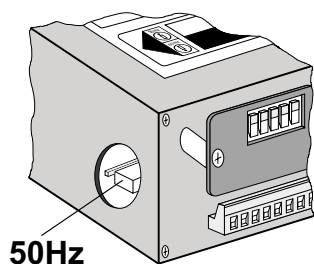

Position the Jumper ⑬ to select 50 or 60Hz frequency

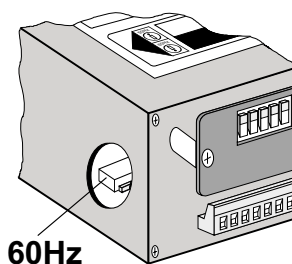

6.3

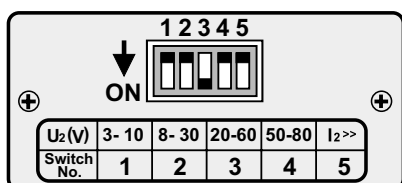

Set the DIP switch ⑮ to the proper secondary voltage range.

NOTE:

With extremely high secondary currents (larger than 80A) DIP switch No.5 must also be on.

Example: With a secondary voltage of 42V and a start up current of 120A ($I_2 \text{ max} = U_2 / R_{HL}$) the DIP switch 3 and 5 must be on.



6.4

Connect the controller as shown in the wiring diagram. No special attention need be given to the polarity of the measuring wires for current and voltage nor for the transformer's primary or secondary wires.

Please see "Installation Instructions "

IMPORTANT:

Make sure that there is **NO** "START" signal, **NO** connection between 2 and 7; **NO** potential on 3.

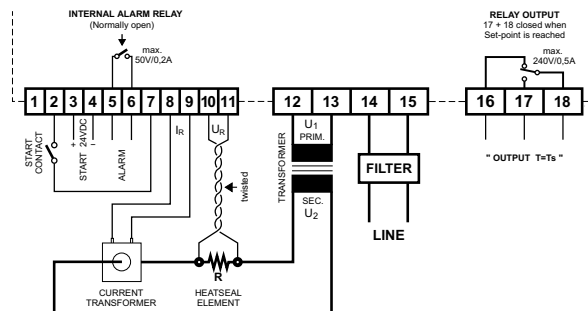
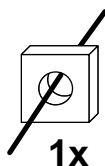

6.5

Connect power. LED "ON" (5) blinks, and LED "Alarm" (7) must be off.

NOTE:

If the controller goes immediately into "Alarm", check

all the wiring to see that it is complete and executed correctly.

If the wiring is correct, see Section "ALARM" for other explanations.

6.6

"ZERO" calibration must only be performed with a heatseal band at ambient temperature.

With the heatseal band at ambient temperature, adjust the Temperature indicator to "Z" by slowly turning the ZERO Potentiometer (2). CW to raise, CCW to lower. If "ZERO" calibration is not possible, (the meter needle remains high), pass the wire through the current transformer a second time; in very extreme cases even a third time. This situation might occur when the heatseal

element is very long or thin (high resistance). After creating additional passes through the current transformer, **recalibrate** the controller.

If calibration is still not possible, recheck all wiring of the complete system for possible errors.



6.7

Set temperature potentiometer to "0". Push "HAND" button (4) to activate the controller. LED "ON" will change from blinking to constant illumination. Slowly increase temperature. The increase in temperature can be observed at the meter. The needle must rise steady and smoothly in response to the temperature changes of the heatseal element both in heating and cooling. After a few heating cycles to approx 250°C, let the element

cool down completely and readjust the "Z" calibration point. (please see "Heatseal Elements"; burn in effect).

The controller is now ready for operation.

NOTE: When turning on the controller, follow the correct sequence. **FIRST**-Power, **THEN** the START signal. **NEVER** both together or in reverse sequence.

However, the temperature may be pre-set before starting the controller.

7

HEATSEAL ELEMENTS

The heatsealing element is an important component of the control system since it is simultaneously the sealing element and the temperature sensor. There are so many different shapes and sizes of heatsealing elements that we cannot discuss them all here, however, some very important physical and electrical characteristics are emphasized here.

- **The controlling principle demands that the alloy of the heatsealing element has the proper temperature co-efficient.**

Therefore only Alloy-20 heatseal bands can be used with the RES controllers. With other heatseal band materials the controller may swing from extreme to extreme, or "run away".

- During the first heat up to 200-250°C the heatseal

band will experience a one time change in resistance (burn in effect). The resistance of the cold element is reduced by approx. 2-3%. This rather small change in resistance however results in a zero point discrepancy of 20-30°. Therefore, it is necessary to readjust the zero point after a few heating cycles.

- A overheated (burned out) heatseal element cannot be used and must be replaced because of an irreversible change in the temperature co-efficient at high temperatures.
- A very important option is to copper plate or silver alloy coat the ends of the heatseal elements. Treated ends remains cold and will result in better temperature control and extend "life" of the heatseal element as well as of the teflon cover or coating.

7.1

Change of Heatseal Elements

After each change of the heatseal element the "Z" point calibration should be readjusted, if necessary, to compensate for possible deviations due to allowable manufacturing tolerances.

8

OPERATING MODES

Depending upon the use of the START signal, two completely different modes of operation can be chosen: **Constant heat** or **Impulse**.

The choice of mode and the correct timing of the impulse sealing will be determined by practical tests with the machine, the product, and the film.

8.1

Constant Heat

The START signal is turned on for the duration of the machine use, and the heatseal element is constantly monitored and maintained at the pre-set temperature. During the sealing phases, the controller automatically compensates for the "lost" heat by increasing the current through the heatseal element. During pauses, only reduced current is necessary to maintain the preset temperature to offset the heat lost into the environment. When the jaws are open, the controller will compensate and overheating is not possible. The constant heat feature is usually used for speeds over 50-60 cycles/minute when the interval between seals is short and cool down time is minimal.

The advantage of this operation method is that the heatseal element must not constantly be reheated. Therefore the demand during the initial heating phase is not as great as during an impulse process. Also there is

less demand upon the heatseal element (less expansion and contraction); the band remains in its expanded condition. The disadvantage of the constant heat is the loss of controlled cool down time while the jaws hold the seal. When the jaws are opened in the warm status, seals tend to shrink or deform.

Generally, when operating with constant heat, the seal is cooled immediately after jaw opening by use of cooling air or a quenching jaw.

When using the "Constant Heat" feature, a fast cool down of the heatseal element is not important, therefore, there should be good thermal insulation between the heatseal element and the jaws. The heat flow into the jaws, and the heating of the jaws, will be reduced. Less total energy will be consumed. The result is less demand on the transformer and the controller.

8.2

Impulse Sealing

The impulse sealing method occurs when the start signal is synchronized with the machine rhythm, every heating phase is followed by a cooling phase **with jaws closed**. Cooling is effected with jaws closed so that the seal has already set and has good strength and appearance when the jaws are opened.

This method is preferred when sealing time is available because seam strength and appearance are better.

Since the impulse heat sealing is a thermodynamic reversible procedure, and is often influenced by time restraints, it is very important that the relevant parameters - temperature, time and pressure - are very carefully synchronized.

The following diagram shows an example of the timely setting of temperature and jaw movement.

Basic rules for impulse heatsealing:

- A. The pre-set temperature should always be attained when the sealing jaws are still open. This allows the sealing element to expand without interference and avoids over-stressing of the ends (phase ②).
- B. The system should be designed to drive the heatseal band to the pre-set temperature in minimum time. However, the maximum rate of temperature rise should not exceed 1°C./mSec. The total system,

principally the secondary voltage, must be optimized to achieve the best result.

Our application service will give you the necessary data for your special application.

- C. The cool down of the heatseal band while still under the force of the jaws is the main advantage of impulse sealing (phase ⑤). After turning off the energy most of the excess heat is absorbed by the jaws. Cooling of the jaws is sometimes recommended so that they can absorb enough heat from the heatseal band quickly. Contrary to the constant heat feature, a good heat flow between the sealing element and the jaws must be assured by using a thin backup material with good thermal conductivity behind the heatseal band.

Under certain conditions, sealing is also possible with the so-called **rest-heat** procedure. During such a phase the remaining heat in a sealing element is calculated to be just enough for the sealing process. This means that in the timing process, the temperature drops in phase ④. The current is cut off when the jaws touch. The heat flows into the film and "unloads" the heatseal band, which results in a fast cooling phase. For this method to be effective the thickness, therefore the mass, of the heatseal band must be great enough to hold the required total heat.

8.2.1

Impulse Sealing Timing

The high thermo-dynamic response of this process demands very exact timing between the controller operation and the heatseal jaws for best results.

Timing chart

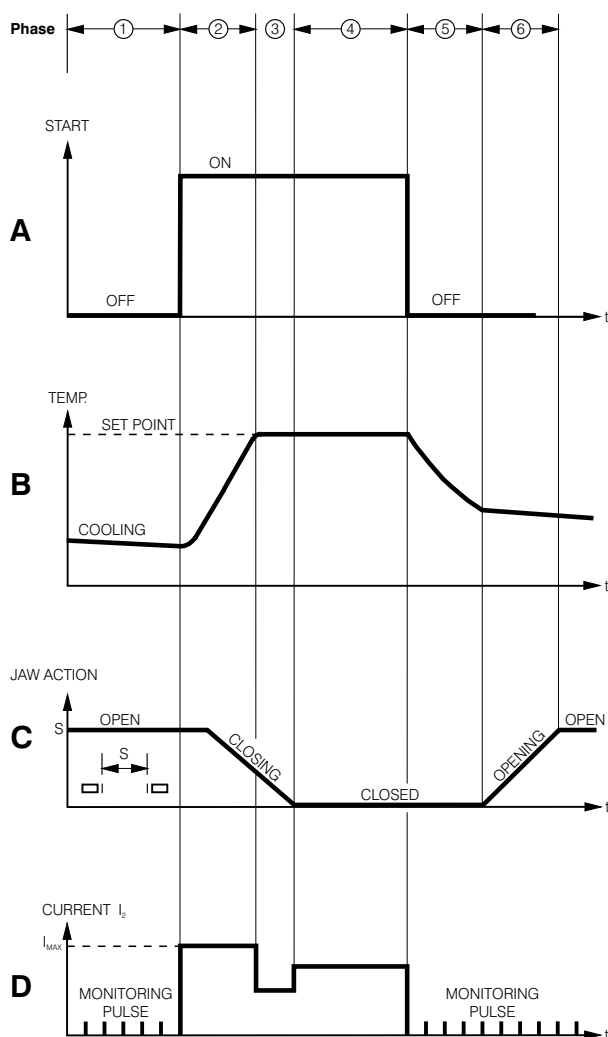

Phase :

- ① **START-Signal is "off"**.
Jaws are open and headseal band is cooling from the previous cycle.
- ② **Start "on"** - Heatseal band temperature rises to the "set point" while jaws are closing. Preferably, the set temperature is reached before jaws totally close.
- ③ Power output is controlled. Temperature remains at "set point". Jaws become completely closed.
- ④ **Sealing Phase** - Sealing time is necessary to achieve a good seal. Power output is controlled. Jaws are closed. Heat is being transferred into the material being sealed.
- ⑤ **Cooling Phase** - Cooling time is needed to achieve a strong seal. Power "off". Heatseal band cools as remaining heat is drawn off into the mass of the jaws. Jaws remain closed.
- ⑥ Jaws are opening. Heatseal band continues to cool.

Diagram D shows the magnitude of current flow during a sealing cycle

- Phase ① : Controller "OFF". LED ⑤ blinks (measuring mode)
- Phase ② : Heating up with maximum power.
- Phase ③ : Regulating to medium power to reach the pre-set temperature before jaws close.
- Phase ④ : Regulating to higher power to maintain the pre-set temperature when heat is drawn from band (sealing)
- Phase ⑤ and Phase ⑥ : Power turned off (cooling). LED ⑤ blinks (measuring mode).

8.3 CYCLE CONTROL using "Set-Point-Reached"-Signal ($T=T_s$)

EXAMPLE

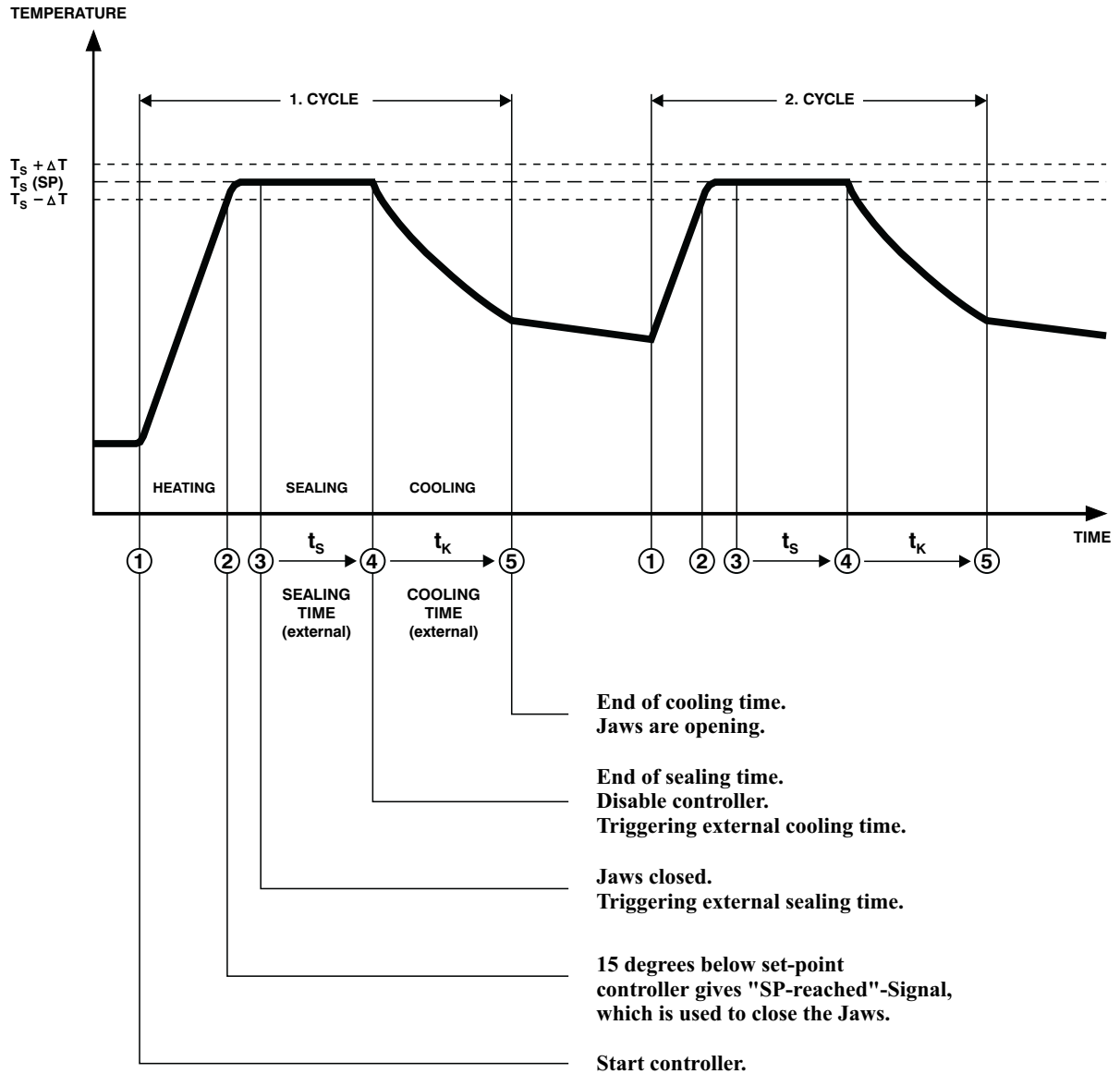

9

PHYSICAL DIMENSIONS

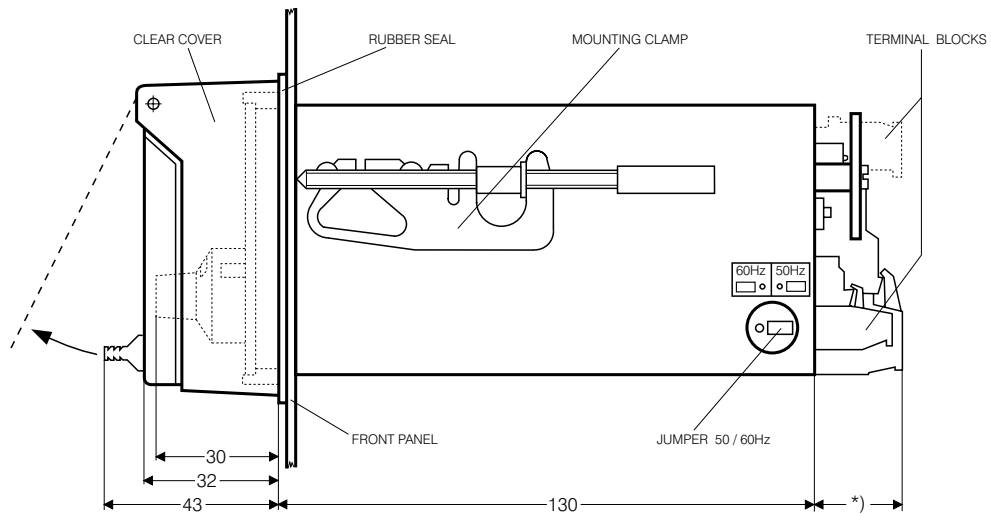

*) 20mm = TYPE RES-XXX - 0
45mm = TYPE RES-XXX - 1

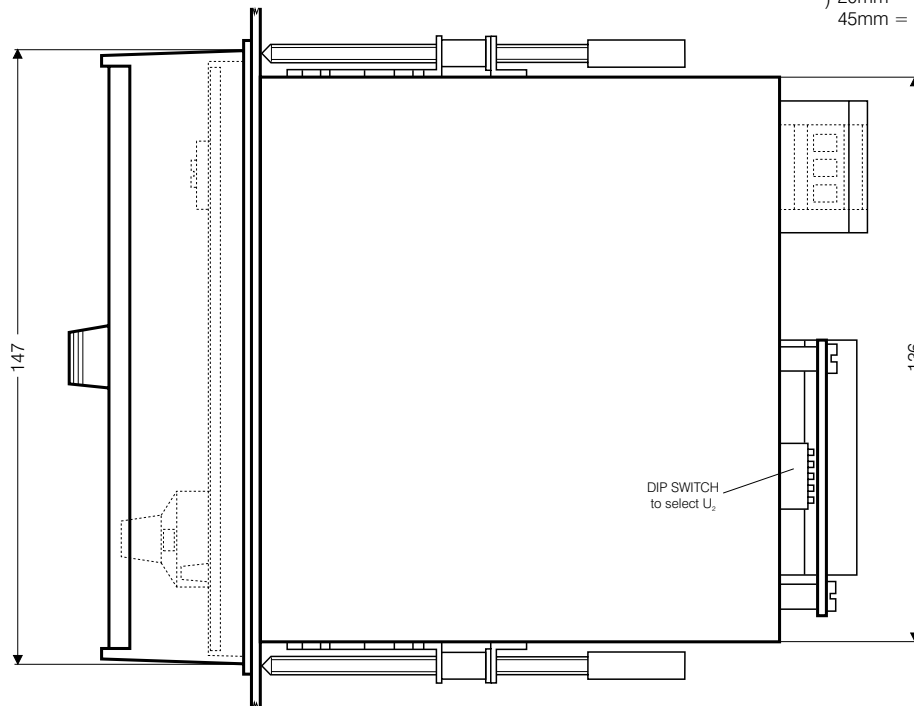

PANEL CUTOUT

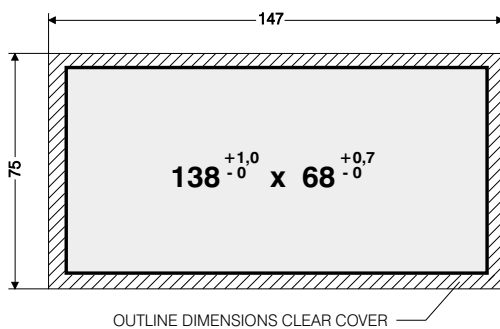

CURRENT TRANSFORMER

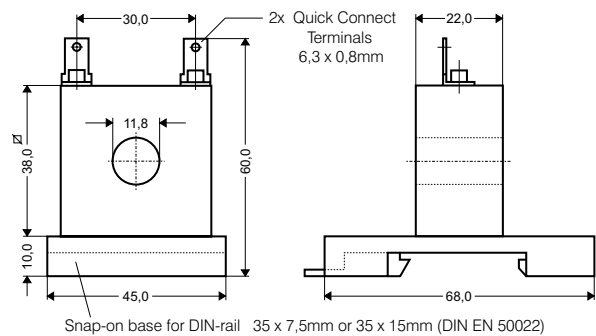

10 TECHNICAL SPECIFICATIONS

- Type of Construction : Housing designed for mounting into the front panel
- Line Voltage** : Standard : 230 VAC
optional : 115 VAC or 400 VAC
- Allowable deviation : +10% / -15%
- Frequency : 50Hz or 60Hz selected with jumper
- Allowable deviation : ±1Hz
- Temperature Control : 10 Turn potentiometer, temperature range 0...300°C (0...500°C)
- Signal
"Set-point reached" : ±15°C temperature band, which travel with set-point
- Output
"Set-point reached" : Relay, dry contact, max.240V/0,5A
- Start Signal,
Terminal 3 and 4 : OFF: 0... 2 VDC, ON : 5...30 VDC; typ. 8 mA at 24V
or
Terminal 2 and 7 : OFF: Contact open ON : Contact closed; typ. 0,13mA
- Alarm Output : Potential free contact, max. 50V / 0,2A; Contact closed when Alarm signal on
- Sampling rate : Every tenth cycle of line voltage in the calibration mode. d.h.: 200 msec at 50Hz
bzw. 166 msec at 60Hz
- Every voltage cycle in controlling mode d.h.: 20 msec at 50Hz
bzw. 16,6 msec at 60Hz
- Calibration : Calibrated for Heatseal Bands with $T_k = +10 \times 10^{-4} K^{-1}$

Max. Primary Current:

Operating Mode	TYPE	
	RES-222-0 (Standard)	RES-222-1
Constant heat	5A	15A
Impulse with 20% duty cycle	25A	20A

 Main Application

- Ambient Temperature : +5°C...+45°C (+41°F...+113°F)
- Electrical connection : terminal blocks, with plug in connectors
- Protective Category : IP 20
- Weigth : Controller 1.30 kg (2.86 Ibs)
Current Transformer 0.15 kg (0.33 Ibs)

10.1

How to Order

Example:

RES-222 - X - X / 230 V - 50/60 Hz

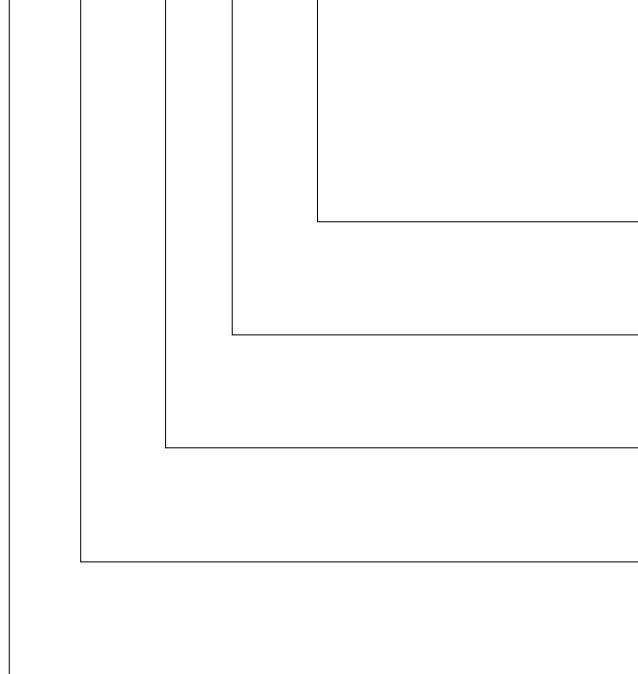

Line Voltage

Standard : 230 VAC
 Option : 115 VAC or 400VAC

Temperature-Range

X = 3 ≙ 0 - 300°C
 X = 5 ≙ 0 - 500°C

Max. Primary Current

X = 0 (see Technical Specifications)
 X = 1

Temperature Display

X = 0 ≙ Analog - Display
 X = 1 ≙ Digital - Display

Model of Controller

- Supply :
- Controller with clear front panel, rubber seal and mouning clamps
 - Current Transformer

INSTALLATION - INSTRUCTIONS

